

PT-150B WIRE CRIMP PULL TESTER



STANDARD FEATURES

- Capacity: 150 lb, 667 N, 68 Kg
- Display units in pounds, newtons or kilograms (dip switch controlled)
- Resolution: 0.1 lb
- Accuracy: $\pm (0.5 \% \text{ Reading} + 1 \text{ Least Significant Digit})$
- Digital Display with Peak Hold
- Backlit LCD Display with 0.56" High Digits
- Self-Tightening Dual Cam Type Upper and Lower Grips
- Lever Arm Pull Mechanism

OPTIONAL FEATURES

- 230 VAC 50/60 Hz Power (P/N 15-7004)

ACCESSORY GRIPS

- Ring Terminal Lower Grip (P/N 15-0066)
- Right Angle Terminal Lower Grip (P/N 15-3042)
- 15 Position Slotted Terminal Lower Grip (P/N 15-3087)
- Extra Wide Self-Tightening Upper Grip (P/N 15-3109)
- Extra Wide Self-Tightening Lower Grip (P/N 15-3108)

PHYSICAL

- Weight 15 Lbs. (Shipping Weight 21 Lbs.)
- Stand Dimensions: H. 15.5", W. 10", D. 16"

CALIBRATION

- New units supplied with certificate of calibration traceable to NIST
- Factory calibration available
- In order to maintain NIST traceability, Do Not Exceed 12 Months Between Calibrations

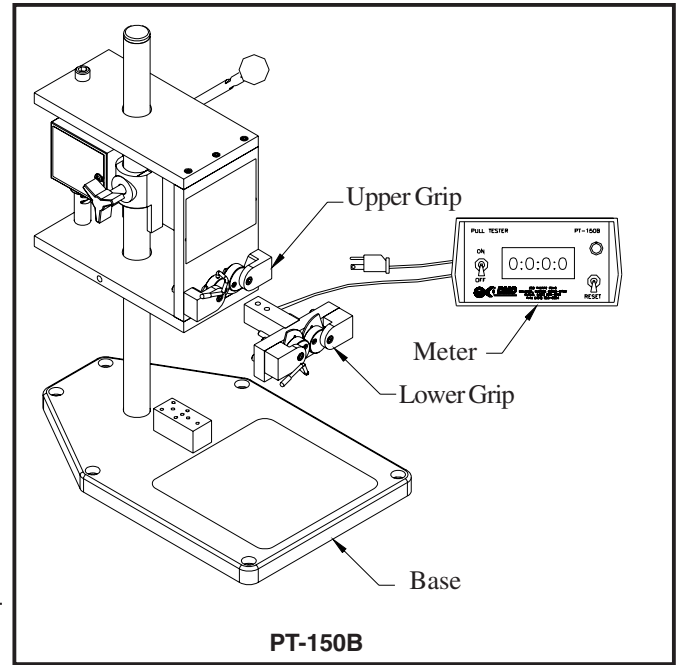

STANDARD GRIPS

SELF-TIGHTENING LOWER GRIP

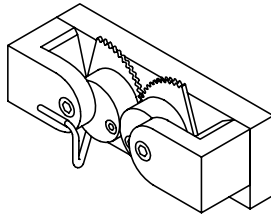

15-3102

SELF-TIGHTENING UPPER GRIP

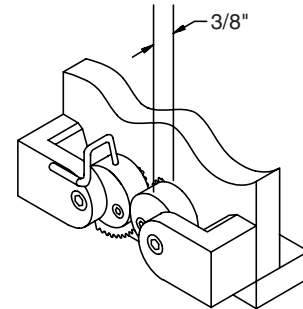

15-3103

ACCESSORY GRIPS

SLOTTED TERMINAL LOWER GRIP

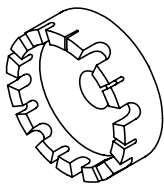

15-3087

Installed Using 15-0065 Screw

SLOT DIMENSION			
1	.031"	9	.094"
2	.250"	10	.188"
3	.047"	11	.110"
4	.236"	12	.172"
5	.063"	13	.125"
6	.218"	14	.158"
7	.080"	15	.141"
8	.203"		

RING TERMINAL LOWER GRIP

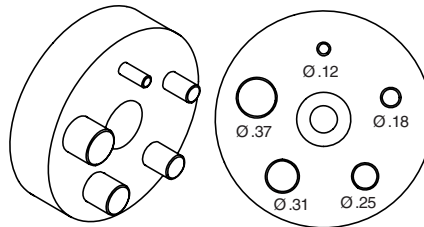

15-0066

Installed Using 15-0065 Screw

EXTRA WIDE UPPER AND LOWER GRIPS (FACTORY INSTALLED ONLY)

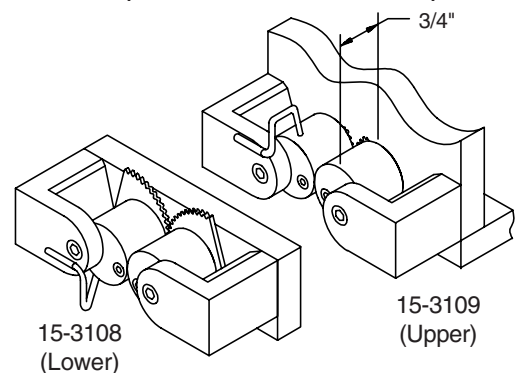

15-3108
(Lower)

15-3109
(Upper)

DANIELS MANUFACTURING CORP., 526 THORPE ROAD, ORLANDO, FL 32824, USA
PHONE (407) 855-6161 • FAX (407) 855-6884 • WWW.DMCTOOLS.COM • E-MAIL: DMC@DMCTOOLS.COM